



## Model 7003 1-3 in Variable Delivery Helm Pump

This pump features adjustable volume in a compact design. Adjustment from 1-3 cubic inches per turn is easily accomplished from the outside. A ball bearing and two thrust bearings provide smooth operation and long life. A lockvalve installed on the back of the helm pump prevents rudder feedback and also allows installation of multiple control stations. The pump normally is supplied in its die cast bronze finish. It can however be ordered in a black epoxy finish.

**Materials:** Housings and rotor are die cast silicon bronze. Pistons and pintol are hardened and ground steel. Pump shaft and hardware are stainless steel.

Weight: 12 lbs. (5.4 kg)

"  
"  
"

"

### ORDERING INFORMATION

A – With cast bronze finish (Standard)

B – With black epoxy finish

L – With long shaft (for behind console mount)

N – With short shaft (for through console mount)

P – With porting block only (no lock valve)

Note: An adapter plate to simplify installation of the helm pump is available. It can be installed on either side of the console.

Ordering number:

7003-0011A (cast bronze finish)

7003-0011B (black epoxy finish)

#### Through console installation with short shaft

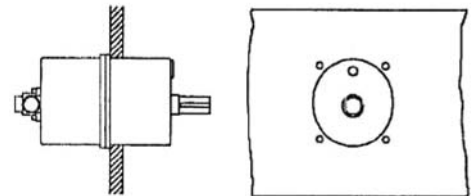

#### Behind console installation with long shaft

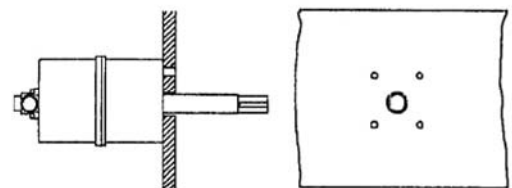

#### Installation with adaptor plate

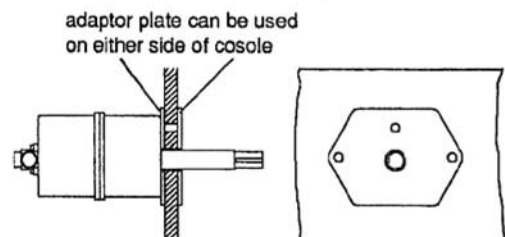

# DIMENSIONS AND PARTS LIST MODEL 7003

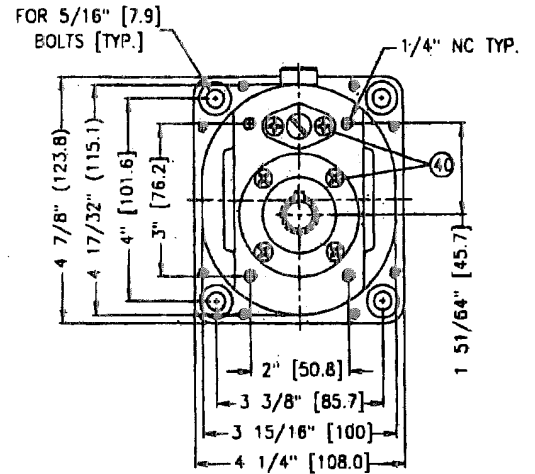
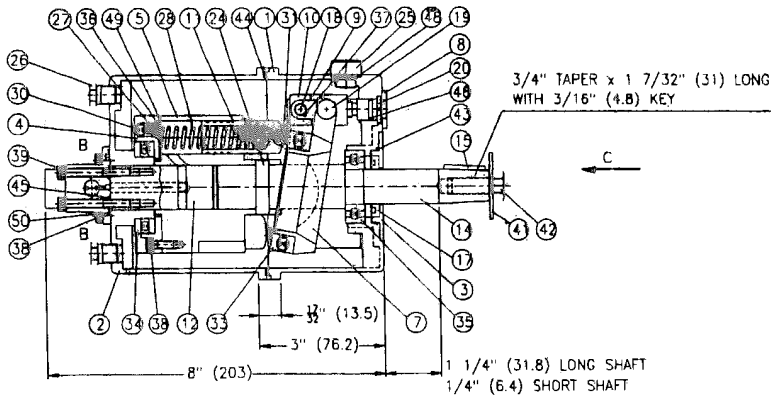

C-VIEW

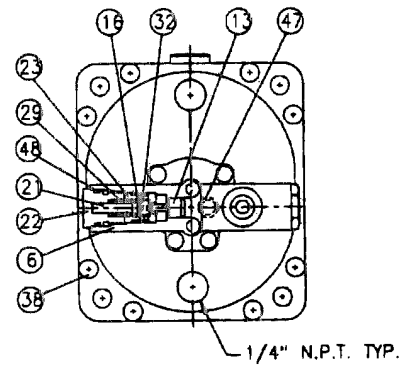

SECTION B-B

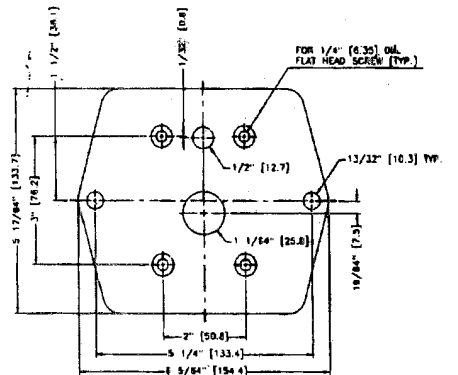

MODEL 7003			
ITEM	QTY	PART NUMBER	DESCRIPTION
1	1	7003-0001	Front Housing
2	1	7003-0002	Rear Housing
3	1	7003-0003	Front Seal Retainer
4	1	7003-0004	Check Valve Housing
5	1	7003-0005	Rotor
6	1	7003-0006	Lock Valve Body
7	1	7003-0007	Thrust Bearing Retainer
8	1	7003-0008	Adjustment Cover Plate
9	2	7005-0009	Link
10	1	7003-0010	Adjustment Block
11	7	7003-0012	Piston
12	1	7003-0013	Pintol
13	1	7003-0014	Shuttle
14	1	7003-0015	Straight Shaft (short)
14	1	7003-0016	Straight Shaft (long)
15	1	7005-0020	Key
16	2	7003-0031	Spring Seat
17	1	7003-7831	Front Seal
18	1	7005-0021	Snap Ring Pin
19	2	7005-0022	Shoulder Bolt
20	1	7003-0023	Adjusting Screw
21	2	7003-0024	Pin
22	2	7003-0025	End cap
23	2	7003-0026	Ball Seat
24	1	7003-0027	Pin
25	1	7003-0028	Filler Plug
25	1	7003-0029	Vented Filler Plug
25	1	7003-0030	Filler Plug with Pipe Thread
26	2	7005-121B	Hex Plug
27	7	1201-0163	Spring
28	7	1201-0170	Spring
29	2	1201-0171	Spring
30	7	1301-0108	Ball Seat
31	7	1301-0112	Ball Seat
32	2	1301-0110	Ball Seat
33	1	7012-51110	Thrust Bearing
34	1	7003-51107	Thrust Bearing
35	1	7003-6004	Ball Bearing
36	7	1029-6037	Self Locking Retaining Ring
37	2	1029-1025	Sbnap Ring
38	19	1002-0808	Socket Hd Cap Screw
39	2	1002-0824	Socket Hd Cap Screw
40	6	1009-0806	Flat Hd Screw
41	1	1023-0248	Washer
42	1	1101-1216	Hex Hd Screw
43	1	1101-0030	"O" Ring
44	1	1101-0156	"O" Ring
45	2	1101-0008	"O" Ring
46	1	1101-0012	"O" Ring
47	2	1101-0010	"O" Ring
48	3	1101-0015	"O" Ring
49	7	1101-0018	"O" Ring
50	1	1101-0026	"O" Ring

Quantity may vary